

Bearing dismounting toolset TP 150

Twin Puller TP 150 – Professional dismounting of deep groove ball bearings and radial shaft seals



The simatool Twin Puller TP 150 can be used to expertly dismount deep groove ball bearings and radial shaft seals. Bearings with a tight fit on the inner or outer ring can be quickly and reliably dismounted with the help of this tool. The TP 150 can also be used to dismount shaft seals, thus making it a unique and professional dismounting tool.

Case contents:

- 6 sets of extraction arms (A1–A6)
- 2 threaded spindles (SW 19)
- Grip handle
- 9 support washers (Ø 10–75 mm)
- Sliding hammer
- Extension for sliding hammer
- 50 tapping screws
- 10 spacer rings

Description and technical data of Twin Puller TP 150

- Suitable for shaft diameters from 10 to 100 mm and external diameters up to 150 mm
- Three dismounting functions in one tool set
- Compact toolset includes a selection table in a handy case
- Perfect complement to the well-proven simatool Fitting Tool FT 33
- Weight of the case 6,6 kg / dimensions (L x W x H) 440 x 350 x 95 mm

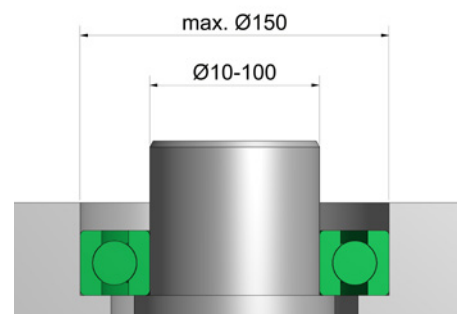
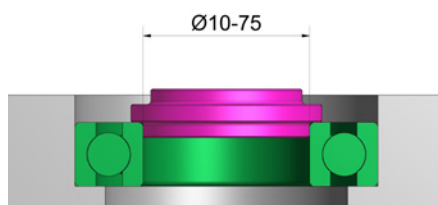
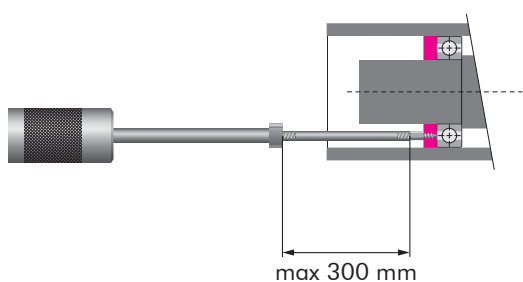

Professional dismounting with Twin Puller TP 150

Removing deep groove ball bearings with a press fit on the inner ring (shaft)

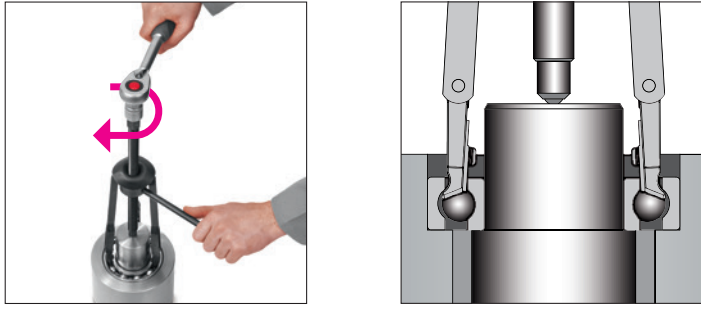

Place the extraction arms between the rolling elements in the bearing. Use the threaded spindle to remove the bearing from the shaft.

Removing deep groove ball bearings with a press fit on the outer ring (housing)

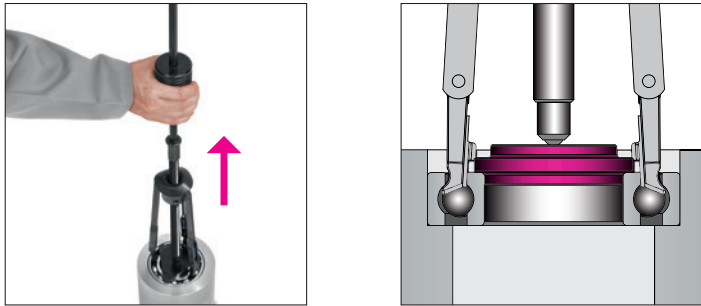

The support washer replaces the shaft on the inner ring and is tensioned using the threaded spindle. Remove the bearing by using the sliding hammer.

Removing radial shaft seals

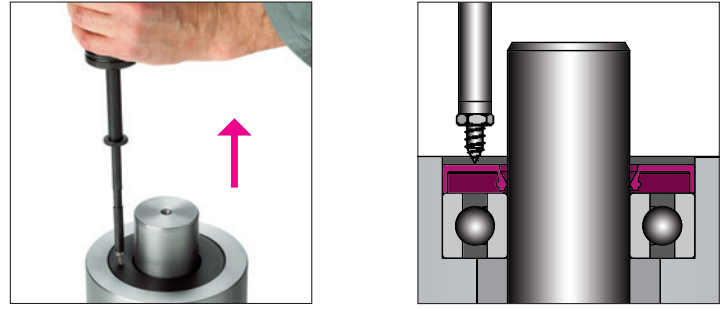

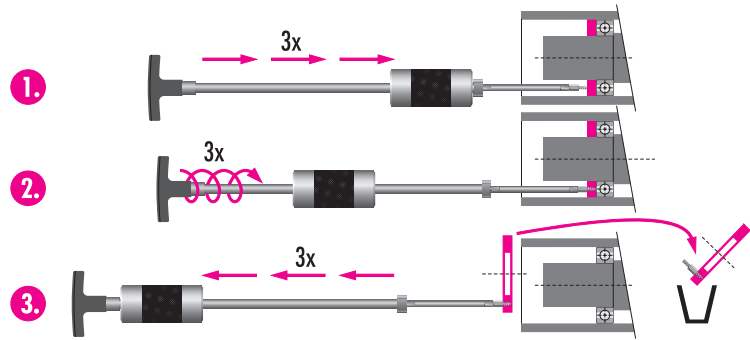

Hammer the tapping screw into the seal and screw it in. Remove the seal by hitting it in the opposite direction with the sliding hammer.



Application videos on www.simatec.com

Selection table Twin Puller TP 150

									
Bearing name								Puller arm	Spindle size
60..	62..	63..		64..					
6000 6001	6002 6003	6200					BP A1	BP M12	
6004 6005	6006	6201 6202 6203	6002				BP A2		
6007 6008	6009 6010	6204 6205		6300 6301	6302		BP A3		
6011 6012	6013	6206		6303 6304			BP A4		
6014 6015	6016 6017	6207 6208 6209	6210 6011	6305 6306 6307		6403	BP A5		
6018 6019	6020	6212 6213 6214	6215 6216 6217	6008 6309 6310	6311 6312 6313	6404 6405 6406 6407	6408 6409 6410		BP A6

Lubrication Equipment B.V.

Jacobus lipsweg 100
 NL-3316 BP Dordrecht
 T: +31 (0)78 - 654 99 66
 E: info@le-bv.nl
 W: www.lubricationequipment.nl